



TUBE

JULY-AUGUST, 1946

HAM NEWS

Copyright 1946, By General Electric Company

VOL. 1—NO. 2



QUICK QRO—CLEAN KEYING

Page 1 & 2—Power Supply Circuit and Details • Page 3—Questions and Answers—Tricks and Topics • Page 4—FG-17 Technical Data

FG-17 Thyratrons Give Variable Output and Grid-phased Keying

ELECTRICAL CIRCUIT

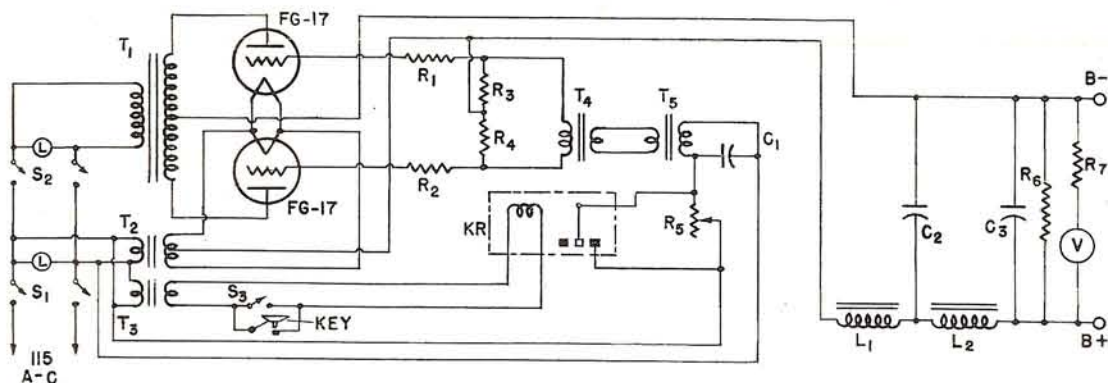

Fig. 1—Circuit Diagram of Power Supply Using Two FG-17 Thyratrons.

CIRCUIT CONSTANTS

C_1 = 0.003 mf. 600 volt mica
 C_2, C_3 = 4 mf. 2000 volt G-E Pyranol
 KR = Keying relay, 6 volt coil
 L = 115 volt pilot lamp
 L_1 = Input choke, 5–20 henry, 500 ma (Thordarson T19C38)
 L_2 = Smoothing choke, 12 henry, 500 ma (Thordarson T19C45)
 R_1, R_2 = 10,000 ohm, 2 watt
 R_3, R_4 = 5,000 ohm, 2 watt
 R_5 = 50,000 ohm, 9 watt potentiometer (Mallory E50MP)
 R_6 = 50,000 ohm, 100 watts

R_7 = Meter multiplier (see "V")
 S_1, S_2 = DPST Heavy-duty a-c switch
 S_3 = SPST toggle switch
 T_1 = 1875, 1560, 0, 1560, 1875, volts @ 500 ma. (Thordarson T19P64)
 T_2 = 2.5 volts @ 10 amps, high-voltage insulation (Thordarson T64F33)
 T_3, T_4, T_5 = 6.3 volts @ 1 amp.
 V = 0–2 kilovolt voltmeter (GE 8DO41V)

The half kilowatt power supply shown in the circuit above and the photograph below (Fig. 2) has been designed for both phone and c-w operation and is rated to deliver 1250 volts at 475 ma. For phone work a small potentiometer permits smooth plate voltage variation from 1250 volts down to approximately 500 volts, allowing rapid power reduction when local QSO's are made. For c-w work, clean and clickless keying is obtained by grid keying of the rectifiers.

Voltage change is accomplished by phasing the grid voltage applied to the General Electric FG-17 thyratrons. The potentiometer used (see Fig. 1 above) allows the output voltage to be changed under full load.

CQ CQ CQ . . .

Lighthouse Larry wants you Hams to submit material for "Questions and Answers" and "Tricks and Topics" (see page three this issue).

Lighthouse Larry wants these two features to be full of live information, so get those letters rolling in. For each "question" or "trick" published in Ham News Lighthouse Larry will award \$10 worth of G-E tubes.

All entries become the property of the Electronics Dept., Tube Division, General Electric Company. What say, gang!

73's
Lighthouse Larry



Fig. 2—Front-panel View of Thyatron Rectifier Power Supply

The power supply may be used to supply plate voltage to a pair of GL-812 tubes in Class C and also supply plate voltage to a pair of GL-811 tubes acting as Class B modulators. If the power is reduced on the final, modulator voltage is similarly reduced.

The change from phone to c-w is made by merely throwing the switch, S₃. Using thyatron grid keying, self-bias may be used for the final instead of fixed bias, and if the driver and oscillator plate voltage is obtained from this same power supply complete break-in operation is possible.

The advantages of thyatron grid keying are many. Key clicks are minimized as the current surge normally experienced is damped by the filter inductance. As a result, the keying envelope is rounded. Further, the keyed circuit consumes practically no power and as a result sparking at the relay contacts is eliminated. Because the key itself makes and breaks only the secondary of a 6-volt transformer, no dangerous voltages are present at the key, and no arcs exist to cause key clicks.

CIRCUIT DETAILS

As may be seen from Fig. 1, the power supply is a standard full-wave rectifier circuit with the addition of the thyatron grid section. The voltage for the grids of the General Electric FG-17 thyatron is obtained from transformers T4 and T5. These 6-volt filament transformers are connected back-to-back, that is, their 6-volt windings are connected together. If a 115-volt (1-1 ratio) transformer is available with high-voltage insulation, it could be substituted for T4 and T5. These transformers are shown in Fig. 3 mounted on a bakelite sub-panel. This is necessary in order to achieve sufficient voltage insulation. Transformers T4 and T5 need not be insulated for high voltage, as ordinary filament transformers have sufficient insulation when used in series as shown.

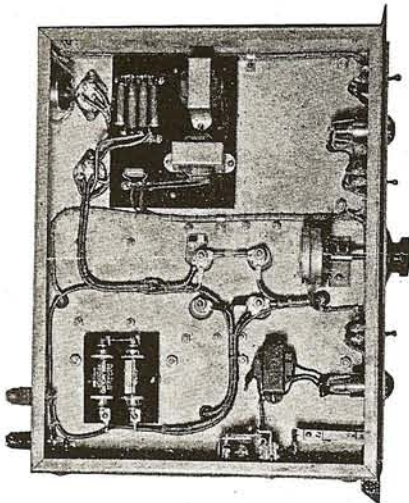

Fig. 3—Bottom View Showing Wiring and Placement of Parts

Resistors R3 and R4 form a center tap and may be omitted if a center-tapped transformer is available. Resistors R1, R2, R3, R4, and capacitor C1 are mounted on the bakelite sub-panel together with transformers T4 and T5. The placement of the other parts is easily seen by reference to Fig. 3 and Fig. 4.

The keying circuit is so wired that with key up conditions, the relay contacts short out R5, giving zero d-c voltage output. Switch S3 may be

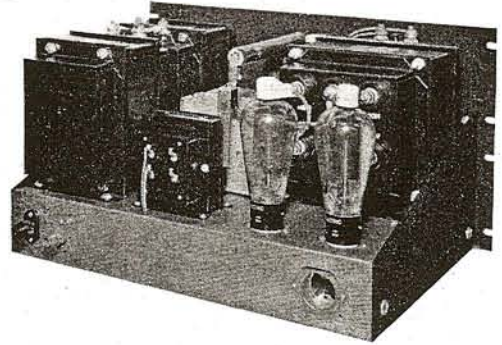

Fig. 4—Rear View Showing Mechanical Arrangement (Note that the power transformer is mounted toward the front panel)

eliminated if a shorting-type jack is used for the key. In this case, the key is plugged in for c-w or removed for phone work.

The entire unit is mounted on a 17 by 13 by 3 inch chassis with a 10½ inch standard relay-rack panel. The voltmeter is recessed for safety reasons.

OPERATION

After the unit is completed it may be necessary to change the connections between transformers T4 and T5 in order to get proper phasing. If a change in the setting of potentiometer R5 produces no change in output voltage, this connection change will cure the trouble.

Higher voltage may be obtained from the power supply by increasing the a-c voltage from the plate transformer. Since the peak forward voltage rating of the FG-17 is 2500 peak volts, the maximum rms voltage from center tap to one side of the transformer should not exceed 1750 volts. If this rating is not observed the FG-17 tubes may be damaged.

Controlling the output voltage by thyatron grid phasing introduces one complication—that of ripple. As the output voltage is lowered the power supply ripple increases. The table of Fig. 5 gives readings of ripple percentage vs output voltage at different loads as experienced with the power supply described.

Voltage (Volts)	Load (ma)	Ripple (per cent)
1250	500	0.12
1250	110	0.09
1000	400	1.4
1000	100	1.2
750	470	4.1
750	250	3.4
500	350	8.8
500	160	7.6

Fig. 5—Table Showing Ripple Percentage vs Output Voltage at Different Loads

QUESTIONS AND ANSWERS



Do you have any questions about tubes or tube circuits? Lighthouse Larry would like to answer them for you. For each question published you will receive \$10 worth of G-E electronic tubes. All questions not published will be answered promptly by mail. Send your questions to Lighthouse Larry, Tube Division, Bldg. 269, General Electric Company, Schenectady, New York or in Canada, to Canadian General Electric Company, Ltd., Toronto, Ont.

Question: Is it possible to run higher plate voltage on a tube when it is used as a Class B audio amplifier than when it is used as a Class C radio-frequency amplifier?—W3IJE

Answer: It is not possible to make a blanket answer to cover all tube types, but in general, the same voltage rating applies to Class B audio as to Class C r-f use. While the tube does not have radio-frequency losses when operated as an audio amplifier, increased ion bombardment of the filament occurs due to the plate voltage being applied over a longer period of time per cycle. This and other factors cause the voltage rating to be the same for these two types of service on most tube types (GL-809, 810, 811, 812, etc.)

Conversely, the plate-voltage ratings for Class C radio-frequency plate-modulated conditions are always less than for Class C radio-frequency power amplifier conditions, due to the increase of voltage which occurs with modulation. In other words, more voltage can be put on tubes in Class B audio

use than on tubes used as Class C r-f plate-modulated amplifiers.—Lighthouse Larry.

Question: Plate voltage for my push-pull 812 final is controlled by means of a switch located in the primary of the plate-supply transformer. With this switch in the off position, why do the 866 rectifier tubes show a glow when radio-frequency excitation is applied to the grids of the 812's?—WILKO

Answer: The glow in your 866 tubes means that in some way, radio-frequency voltage is passing through your rectifiers. This condition could exist if the final were not completely neutralized. In this case, r-f energy could pass along the B+ line (through or around your r-f choke) into the filaments of the 866 tubes, through the tubes and plate transformer and back to ground. This may be cured by re-neutralizing, and making sure that the B+ lead is connected to the exact electrical center of the tank coil. Also, be sure your r-f choke is good for the frequency band you are using.

The condition described might also be caused by r-f pickup somewhere in the power supply, due to inadequate r-f shielding. This is not too likely, however.

In either case this condition of glow in the 866 tubes should be corrected, as the glow may reduce the inverse voltage breakdown and cause short life.—Lighthouse Larry.



TRICKS AND TOPICS

How did you solve that last problem that almost had you stumped? Be it about tubes, antennas, circuits, etc., Lighthouse Larry would like to tell the rest of the hams about it. Send it in! For each "trick" accepted you win \$10 worth of G-E Electronic Tubes. No entries returned. Submit to Lighthouse Larry, Tube Division, Bldg. 269, General Electric Company, Schenectady, New York or in Canada, to Canadian General Electric Company, Ltd., Toronto, Ont.

Crystal Socket Trick

Using these new tiny crystal holders that plug into a standard octal socket, it is easily possible to plug the holder in the wrong way unless the socket is wired so that no mistake may be made. Here is the way I solved the problem. Connect pins 1, 2, 5 and 6 together as one lead. Connect pins 3, 4, 7 and 8 together as the other lead from the socket. Wired in this manner, the crystal holder may be plugged into any of the pins and will still be properly connected. Further, a second holder is also properly connected when inserted.—W9CLF.

Meter Shunt Trick

It is generally agreed that metering in the negative high-voltage lead is by far the safest method yet devised. Its one disadvantage—that of reading the total cathode current—may easily

be overcome. All that is necessary is a meter shunt of just the right value to lower the meter reading by the amount of the grid current (or grid plus screen current in the case of a screen-grid tube). Assuming that the transmitter contains a grid meter, it is only necessary to put low value (one or two ohm) resistors across the cathode meter until the reading is reduced by the value of grid current. As long as the drive stays constant, the cathode meter will then read plate current only.—W4BAN

Neutralizing Trick

Recently I completed a rig using a pair of 807 tubes in the final. Extreme care was taken to shield grid and plate circuits and everything was properly by-passed. However, the 807 tubes still oscillated madly by themselves. After practically rebuilding the final twice with no better results, neutralizing was tried—with worse results. As a last resort the neutralizing condensers were connected in parallel with the tubes; that is, directly from grid to plate on each tube. The result was perfect neutralization. Evidently the circuit caused the tubes to be over-neutralized, and additional grid to plate capacity was required to get stable operation.—W9DEX/O

TECHNICAL INFORMATION

GENERAL CHARACTERISTICS

FG-17

Number of electrodes 3

Electrical

Cathode—Filamentary type
 Filament voltage 2.5 volts
 Filament current, approx. 5.0 amperes
 Filament heating time, typical. 5 seconds
 Peak voltage drop, typical. 16 volts
 Approximate control characteristics
 Anode voltage 40 100 1000 volts
 Grid voltage 0 -2.25 -6.50 volts
 Anode to grid capacitance, approx. 4.4 micromicrofarads
 Ionization time, approx. 10 microseconds
 De-ionization time, approx. 1000 microseconds

Mechanical

Net weight, approx. 3 ounces
 Shipping weight, approx. 3 pounds
 Mounting position. vertical, base down

MAXIMUM RATINGS

Maximum peak anode voltage
 Inverse 5000 volts
 Forward. 2500 volts
 Maximum negative grid voltage
 Before conduction 500 volts
 During conduction. 10 volts
 Maximum anode current
 Instantaneous, 25 cycles and above. 2.0 amperes
 Instantaneous, below 25 cycles. 1.0 ampere
 Average 0.5 ampere
 Surge, for design only. 40 amperes
 Duration of surge current. 0.1 second
 Maximum grid current
 Instantaneous 0.25 ampere
 Average 0.05 ampere
 Maximum time of averaging current. 15 seconds
 Temperature limits, condensed mercury +40 to +80 centigrade
 Recommended temperature, condensed mercury +40 centigrade

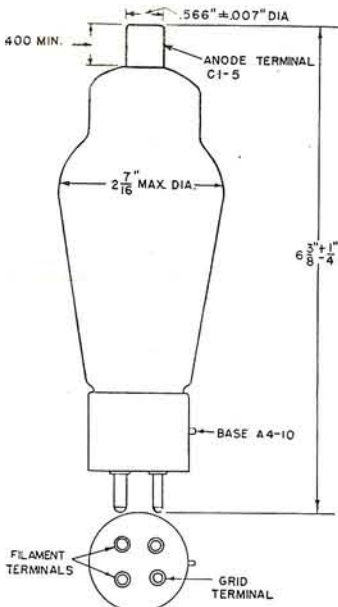

OUTLINE
 FG-17 THYRATRON

The FG-17 thyatron is a negative-control mercury-vapor tube for use where it is desired to actuate the tube with a change in negative grid voltage. It requires relatively little grid power and is suitable for use in relay circuits where current flow is desired in the absence of grid excitation.

UNITED RADIO INC.
 1314 VINE ST. CIN. O.
 WHOLESALE DISTRIBUTORS

Space for Dealer Imprint

Electronics Department
GENERAL ELECTRIC

Schenectady, N. Y.

(In Canada, Canadian General Electric Company, Ltd; Toronto, Ont.)